

FEDERAL SUPPLY CLASS  
5306

REV.  
B

RATIONALE

FIGURE REDRAWN TO CONFORM TO AS1132, USAGE NOTE ADDED, SPECS UPDATED.

NOTICE

THE INITIAL SAE PUBLICATION OF THIS DOCUMENT WAS TAKEN DIRECTLY FROM U.S. MILITARY STANDARD MS9638, NOTICE 1. THIS SAE STANDARD MAY RETAIN THE SAME PART NUMBERS ESTABLISHED BY THE ORIGINAL MILITARY DOCUMENT.

ANY REQUIREMENTS ASSOCIATED WITH QUALIFIED PRODUCTS LISTS (QPL'S) MAY CONTINUE TO BE MANDATORY FOR DoD CONTRACTS. REQUIREMENTS RELATING TO QPL'S HAVE NOT BEEN ADOPTED BY THE SAE FOR THIS STANDARD AND ARE NOT PART OF THIS SAE DOCUMENT.

SAE Technical Standards Board Rules provide that: "This report is published by SAE to advance the state of technical and engineering sciences. The use of this report is entirely voluntary, and its applicability and suitability for any particular use, including any patent infringement arising therefrom, is the sole responsibility of the user." SAE invites your written comments and suggestions. SAE reviews each technical report at least every five years at which time it may be revised, reaffirmed, stabilized, or cancelled.

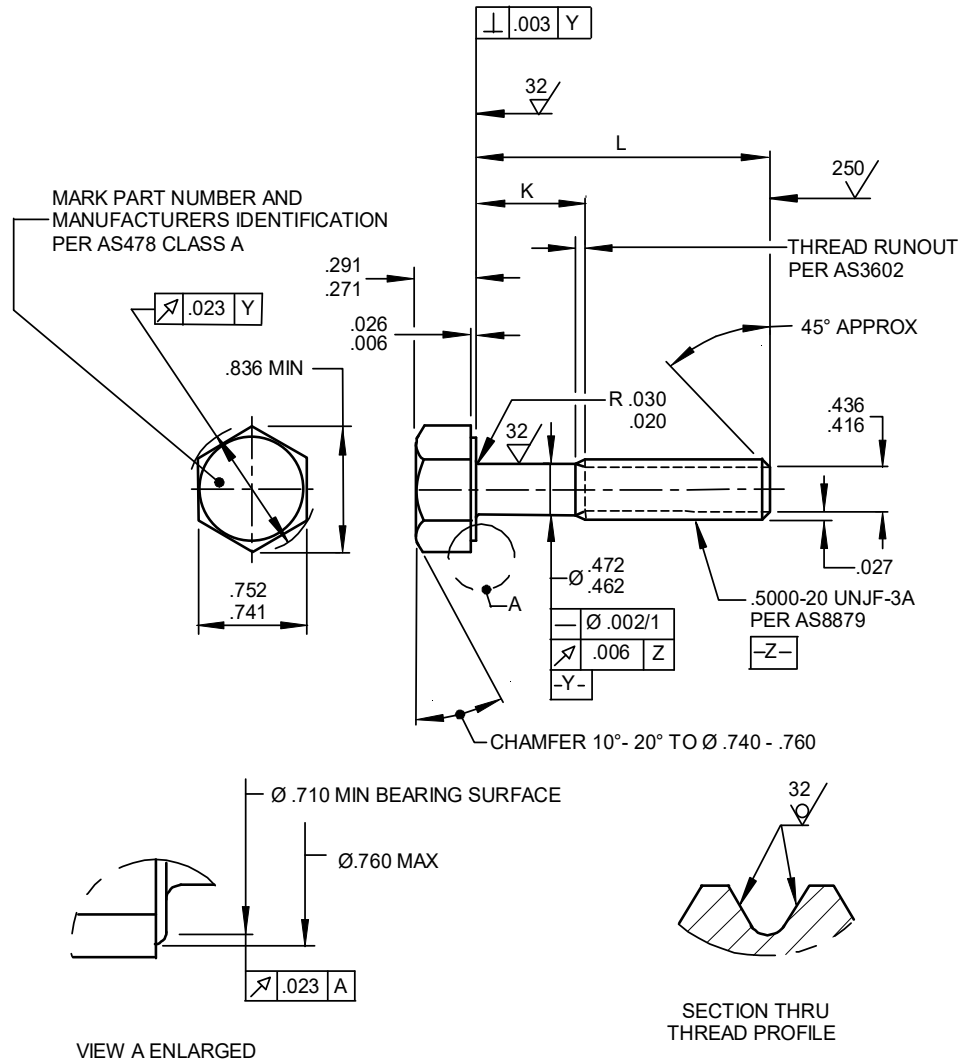
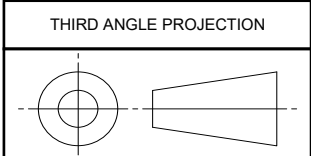

FIGURE 1 - BOLT

For more information on this standard, visit  
<https://www.sae.org/standards/content/AS9638B>



CUSTODIAN: E-25

PROCUREMENT SPECIFICATION: AS7461



**AEROSPACE STANDARD**

BOLT, MACHINE - HEXAGON HEAD,  
PD SHANK, TITANIUM AMS4967 (UNS R56400),  
.500-20 UNJF-3A

AS9638™  
SHEET 1 OF 3

REV.  
B

ISSUED 1998-08 REAFFIRMED 2018-08 REVISED 2020-03